





# BETTEREDGE INTRODUCES THE RAPID EDGE ⚡ PROGRAM

Get the **HIGH PERFORMANCE TOOLS**  
you want for the exact application  
when you need it.

**BETTEREDGE = BETTER PERFORMANCE**

## 3 day Delivery Commitment

- » Straight Stock Endmill modified with
- » custom radius, ball, Necked Down, etc.
- » Must Order before 10 a.m.

## 1 Week Delivery Commitment

- » Step drills, 1 and 2 step
- » Tools Coated to your choice
- » Must Order before 10 a.m.  
for guaranteed delivery



ISO 9001:2015  
CERTIFIED COMPANY

 **PRI Registrar**  
PERFORMANCE REVIEW INSTITUTE



FOLLOW US ON 



For more info call: **866.887.5546** Or Visit: **www.Better-Edge.com**

STEP DRILLS

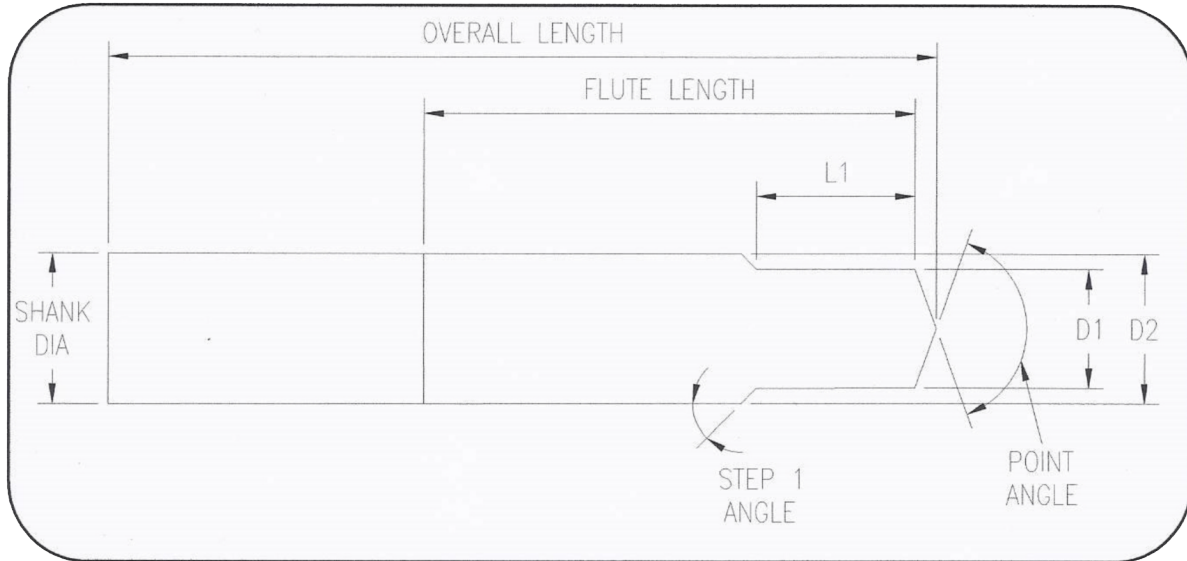

Overall Length: \_\_\_\_\_  
 Flute Length: \_\_\_\_\_  
 Shank Dia.: \_\_\_\_\_  
 D1: \_\_\_\_\_  
 D2: \_\_\_\_\_

Point Angle: \_\_\_\_\_  
 L1: \_\_\_\_\_  
 Step 1 Angle: \_\_\_\_\_  
 Coating: \_\_\_\_\_  
 Flute Type:     Straight     Spiral  
 Coolant Holes:     Yes     No  
 Material Being Machined: \_\_\_\_\_

Name: \_\_\_\_\_  
 Company Name: \_\_\_\_\_  
 Address: \_\_\_\_\_  
 \_\_\_\_\_  
 Phone #: \_\_\_\_\_  
 Fax #: \_\_\_\_\_  
 e-Mail: \_\_\_\_\_

END MILLS

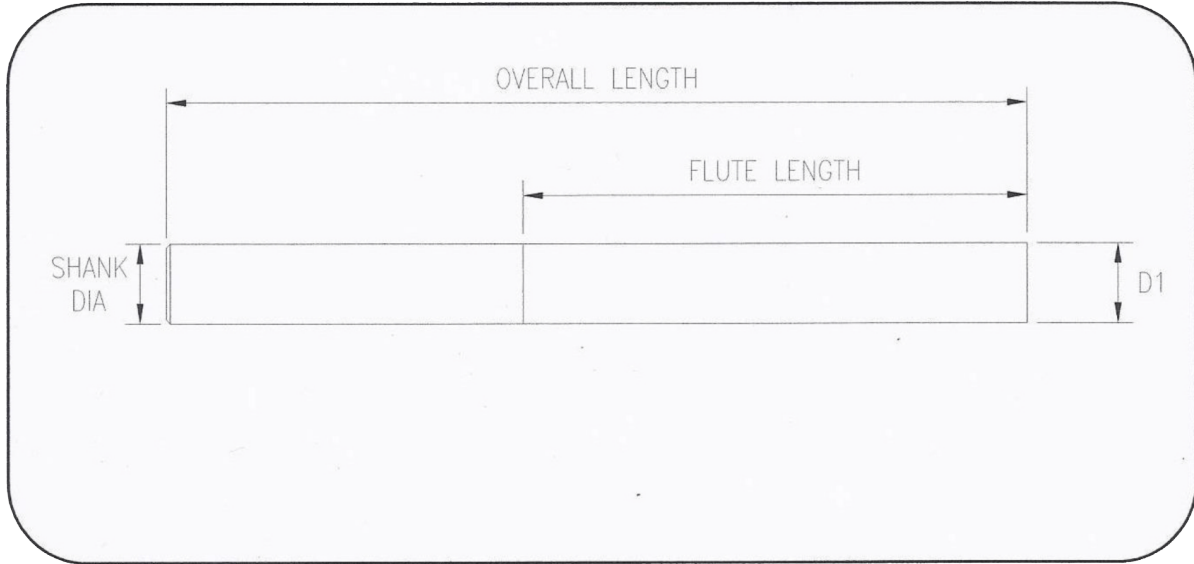

Overall Length: \_\_\_\_\_  
 Flute Length: \_\_\_\_\_  
 Shank Dia.: \_\_\_\_\_  
 D1: \_\_\_\_\_

Number of Flutes: \_\_\_\_\_  
 Corner Radius:  Yes  No Size: \_\_\_\_\_  
 \_\_\_\_\_  
 \_\_\_\_\_

Name: \_\_\_\_\_  
 Company Name: \_\_\_\_\_  
 Address: \_\_\_\_\_  
 \_\_\_\_\_  
 Phone #: \_\_\_\_\_  
 Fax #: \_\_\_\_\_  
 e-Mail: \_\_\_\_\_

DRILL'S

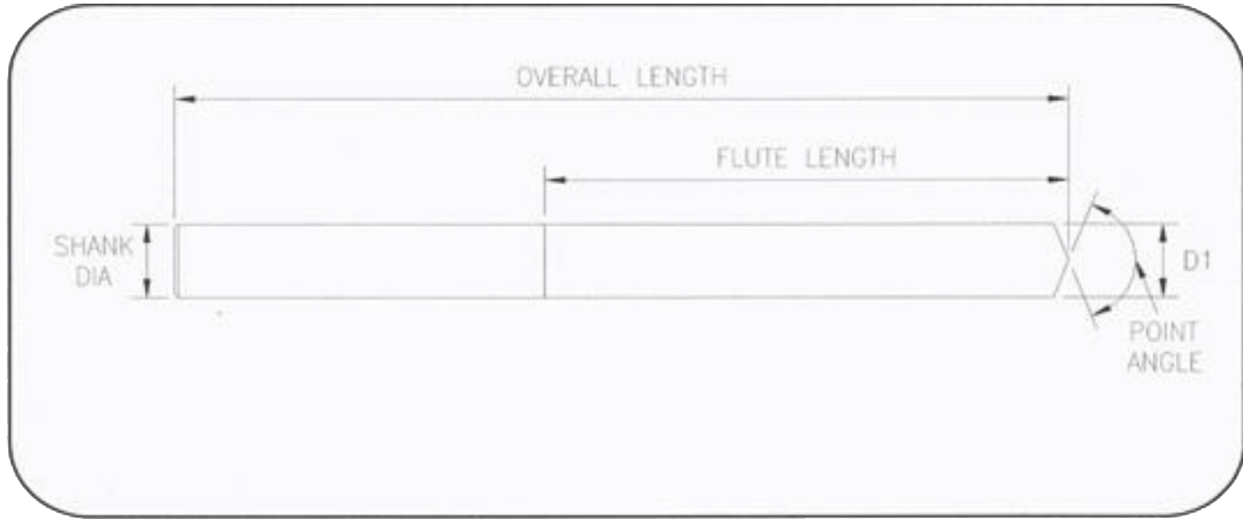

Overall Length: \_\_\_\_\_  
 Flute Length: \_\_\_\_\_  
 Shank Dia.: \_\_\_\_\_  
 D1: \_\_\_\_\_  
 D2: \_\_\_\_\_

Point Angle: \_\_\_\_\_  
 Coating: \_\_\_\_\_  
 Flute Type:     Straight     Spiral  
 Coolant Holes:     Yes     No  
 Material Being Machined: \_\_\_\_\_

Name: \_\_\_\_\_  
 Company Name: \_\_\_\_\_  
 Address: \_\_\_\_\_  
 \_\_\_\_\_  
 Phone #: \_\_\_\_\_  
 Fax #: \_\_\_\_\_  
 e-Mail: \_\_\_\_\_