

DESCRIPTION EXAMPLE... I=INCH, N=NON FERROUS, S=SOLID, 3=FLUTES, 125=DIA, 5XD=FLUTE LENGTH	DRILL DIAMETER D1 inch m7	DRILLS FRACTIONAL & FOR THREADS	SHANK DIAMETER D2 metric	OAL L1 inch	FLUTE LENGTH L2 inch	DRILLING DEPTH L3 inch	SHANK LENGTH L4 inch
INS3-1250-5XD	.125	1/8	6	2.598	1.063	0.906	1.417
INS3-1406-5XD	.141	9/64	6	2.598	1.102	0.906	1.417
INS3-1540-5XD	.154	10-24 UNC	6	2.913	1.339	1.142	1.417
INS3-1562-5XD	.156	5/32	6	2.913	1.339	1.142	1.417
INS3-1610-5XD	.161	10-32 UNF	6	2.913	1.378	1.142	1.417
INS3-1690-5XD	.169	M5	6	2.913	1.378	1.142	1.417
INS3-1719-5XD	.172	11/64	6	2.913	1.378	1.142	1.417
INS3-1875-5XD	.188	3/16	6	3.228	1.654	1.378	1.417
INS3-1890-5XD	.189	12-32 UNF	6	3.228	1.654	1.378	1.417
INS3-2010-5XD	.201	M6	6	3.228	1.654	1.378	1.417
INS3-2031-5XD	.203	13/64	6	3.228	1.654	1.378	1.417
INS3-2188-5XD	.219	7/32	6	3.228	1.693	1.378	1.417
INS3-2344-5XD	.234	15/64	6	3.228	1.693	1.378	1.417
INS3-2500-5XD	.250	1/4	8	3.583	2.047	1.693	1.417
INS3-2640-5XD	.264	5/18-18UNF	8	3.583	2.087	1.693	1.417
INS3-2656-5XD	.266	17/64	8	3.583	2.087	1.693	1.417
INS3-2800-5XD	.280	MF8x1	8	3.583	2.087	1.693	1.417
INS3-2813-5XD	.281	9/32	8	3.583	2.087	1.693	1.417
INS3-2969-5XD	.297	19/64	8	3.583	2.126	1.693	1.417
INS3-3125-5XD	.313	5/16	8	3.583	2.126	1.693	1.417
INS3-3281-5XD	.328	21/64	10	4.055	2.402	1.929	1.575
INS3-3438-5XD	.344	11/32	10	4.055	2.441	1.929	1.575
INS3-3594-5XD	.359	23/64	10	4.055	2.441	1.929	1.575
INS3-3750-5XD	.375	3/8	10	4.055	2.480	1.929	1.575

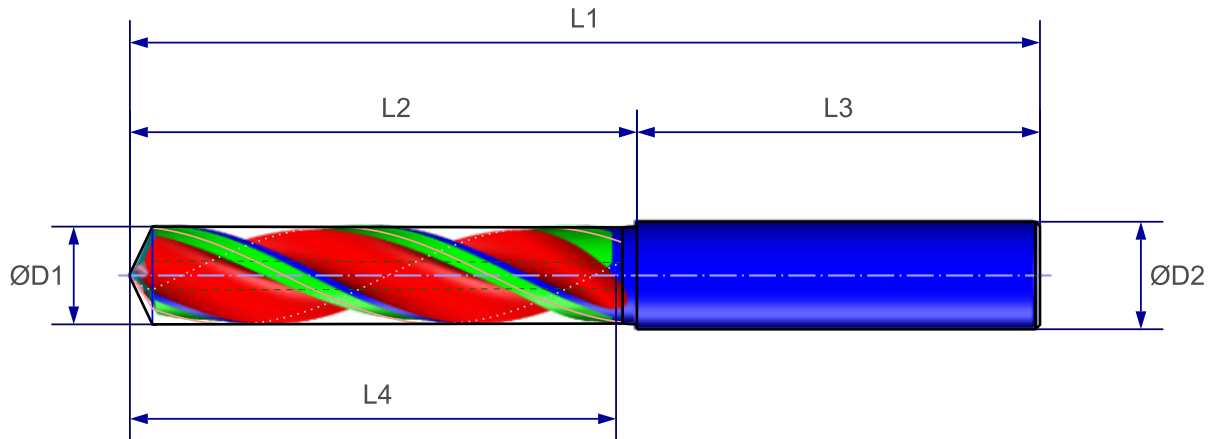

INS3-3906-5XD	.391	25/64	10	4.055	2.480	1.929	1.575
INS3-3940-5XD	.394	7/16-20 UNF	12	4.646	2.795	2.205	1.575
INS3-4063-5XD	.406	13/32	12	4.646	2.795	2.205	1.772
INS3-4210-5XD	.421	MF12x1.5	12	4.646	2.835	2.205	1.772
INS3-4375-5XD	.438	7/16	12	4.646	2.835	2.205	1.772
INS3-4531-5XD	.453	29/64	12	4.646	2.874	2.205	1.772
INS3-4570-5XD	.457	1/2-20 UNF	12	4.646	2.874	2.205	1.772
INS3-4690-5XD	.469	15/32	12	4.646	2.874	2.205	1.772
INS3-4844-5XD	.484	31/64	14	4.882	3.071	2.362	1.772
INS3-5000-5XD	.500	1/2	14	4.882	3.110	2.362	1.772
INS3-5469-5XD	.547	35/64	14	4.882	3.150	2.362	1.89
INS3-5625-5XD	.563	9/16	16	5.236	3.307	2.480	1.89
INS3-5781-5XD	.578	37/64	16	5.236	3.346	2.480	1.91
INS3-5938-5XD	.594	19/32	16	5.236	3.346	2.480	1.91
INS3-6094-5XD	.609	39/64	16	5.236	3.386	2.480	1.91
INS3-6250-5XD	.625	5/8	16	5.236	3.386	2.480	1.91
INS3-6875-5XD	.688	11/16	18	5.630	3.819	2.795	1.91
INS3-7500-5XD	.750	3/4	20	6.024	4.134	3.031	1.99

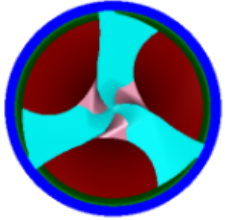
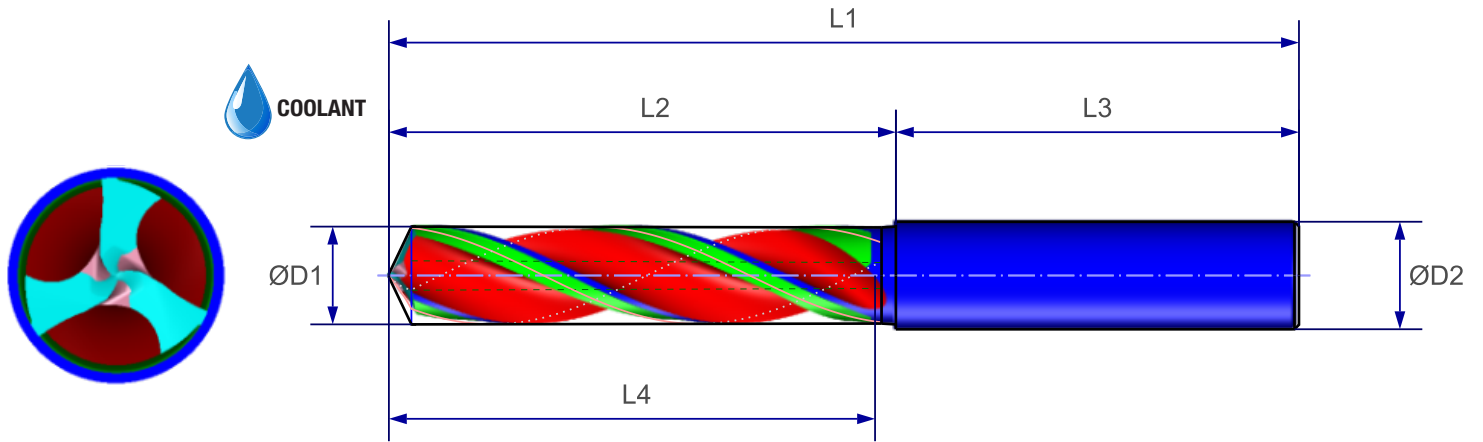

DESCRIPTION EXAMPLE... I=INCH, N= NON FERROUS, C=COOLANT, 3=FLUTES, 125=DIA, 5XD=FLUTE LENGTH	DRILL DIAMETER D1 inch m7	DRILLS FRACTIONAL & FOR THREADS	SHANK DIAMETER D2 metric	OAL L1 metric	FLUTE LENGTH L2 inch	DRILLING DEPTH L3 inch	SHANK LENGTH L4 inch
INS3-1875-5XD	.188	3/16	6	3.228	1.654	1.378	1.417
INS3-1890-5XD	.189	12-32 UNF	6	3.228	1.654	1.378	1.417
INS3-2010-5XD	.201	M6	6	3.228	1.654	1.378	1.417
INS3-2031-5XD	.203	13/64	6	3.228	1.654	1.378	1.417
INS3-2188-5XD	.219	7/32	6	3.228	1.693	1.378	1.417
INS3-2344-5XD	.234	15/64	6	3.228	1.693	1.378	1.417
INS3-2500-5XD	.250	1/4	8	3.583	2.047	1.693	1.417
INS3-2640-5XD	.264	5/18-18UNF	8	3.583	2.087	1.693	1.417
INS3-2656-5XD	.266	17/64	8	3.583	2.087	1.693	1.417
INS3-2800-5XD	.280	MF8x1	8	3.583	2.087	1.693	1.417
INS3-2813-5XD	.281	9/32	8	3.583	2.087	1.693	1.417
INS3-2969-5XD	.297	19/64	8	3.583	2.126	1.693	1.417
INS3-3125-5XD	.313	5/16	8	3.583	2.126	1.693	1.417
INS3-3281-5XD	.328	21/64	10	4.055	2.402	1.929	1.575
INS3-3438-5XD	.344	11/32	10	4.055	2.441	1.929	1.575
INS3-3594-5XD	.359	23/64	10	4.055	2.441	1.929	1.575
INS3-3750-5XD	.375	3/8	10	4.055	2.480	1.929	1.575
INS3-3906-5XD	.391	25/64	10	4.055	2.480	1.929	1.575
INS3-3940-5XD	.394	7/16-20 UNF	12	4.646	2.795	2.205	1.575
INS3-4063-5XD	.406	13/32	12	4.646	2.795	2.205	1.772
INS3-4210-5XD	.421	MF12x1.5	12	4.646	2.835	2.205	1.772
INS3-4375-5XD	.438	7/16	12	4.646	2.835	2.205	1.772
INS3-4531-5XD	.453	29/64	12	4.646	2.874	2.205	1.772
INS3-4570-5XD	.457	1/2-20 UNF	12	4.646	2.874	2.205	1.772

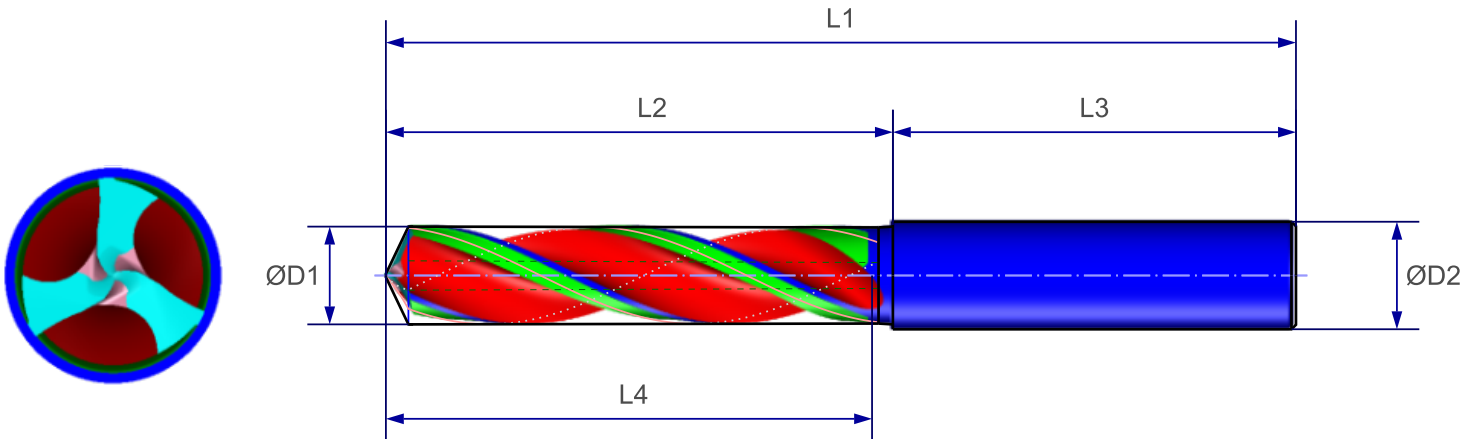

DESCRIPTION EXAMPLE... M=METRIC, N=NON FERROUS, S=SOLID, 3=FLUTES, 3=Metric DIA 5XD=FLUTE LENGTH	DRILL DIAMETER D1 mm m7	DRILLS FOR THREADS	SHANK DIAM- ETER D2	OAL L1 mm	FLUTE LENGTH L2 mm	DRILLING DEPTH L3 mm	SHANK LENGTH L4 mm
MNS3-0300-5XD	3.00		6	66	27	23	36
MNS3-0310-5XD	3.10		6	66	27	23	36
MNS3-0320-5XD	3.20		6	66	27	23	36
MNS3-0330-5XD	3.30		6	66	27	23	36
MNS3-0340-5XD	3.40	M4	6	66	28	23	36
MNS3-0350-5XD	3.50		6	66	28	23	36
MNS3-0360-5XD	3.60		6	66	28	23	36
MNS3-0370-5XD	3.70		6	66	28	23	36
MNS3-0380-5XD	3.80		6	74	34	29	36
MNS3-0390-5XD	3.90	10-24 UNC	6	74	34	29	36
MNS3-0400-5XD	4.00		6	74	35	29	36
MNS3-0410-5XD	4.10	10-32 UNC	6	74	35	29	36
MNS3-0420-5XD	4.20		6	74	35	29	36
MNS3-0430-5XD	4.30	M5	6	74	35	29	36
MNS3-0440-5XD	4.40		6	74	35	29	36
MNS3-0450-5XD	4.50		6	74	35	29	36
MNS3-0470-5XD	4.70		6	74	36	29	36
MNS3-0480-5XD	4.80	12-32 UNC	6	82	42	35	36
MNS3-0490-5XD	4.90		6	82	42	35	36
MNS3-0500-5XD	5.00		6	82	42	35	36
MNS3-0510-5XD	5.10	M6	6	82	42	35	36
MNS3-0520-5XD	5.20		6	82	42	35	36
MNS3-0530-5XD	5.30	1/4-20 UNC	6	82	42	35	36
MNS3-0540-5XD	5.40		6	82	43	35	36

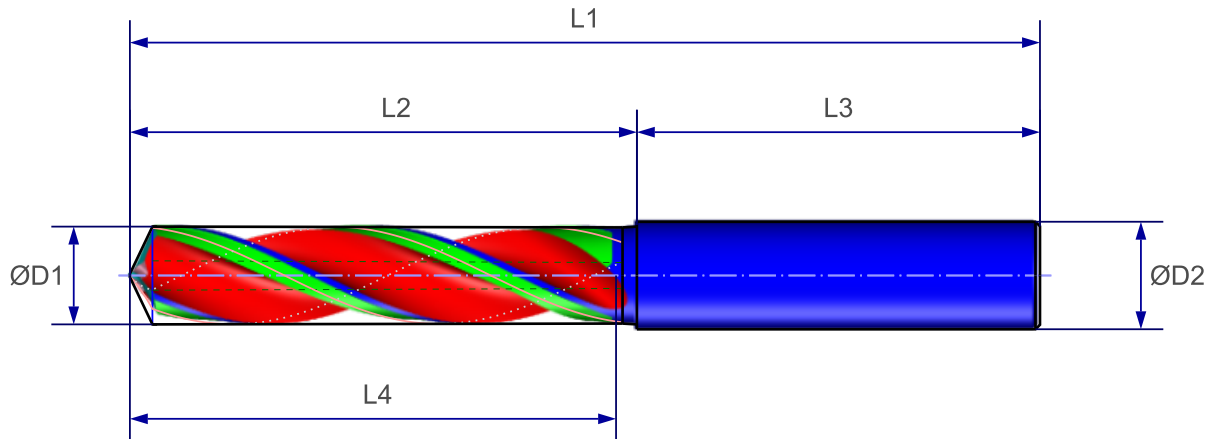
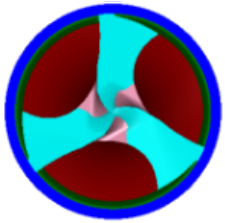

MNS3-0550-5XD	5.50		6	82	43	35	36
MNS3-0560-5XD	5.60		6	82	43	35	36
MNS3-0570-5XD	5.70		6	82	43	35	36
MNS3-0580-5XD	5.80		6	82	43	35	36
MNS3-0590-5XD	5.90		6	82	43	35	36
MNS3-0600-5XD	6.00		8	91	52	43	36
MNS3-0610-5XD	6.10		8	91	52	43	36
MNS3-0620-5XD	6.20		8	91	52	43	36
MNS3-0630-5XD	6.30		8	91	52	43	36
MNS3-0640-5XD	6.40		8	91	52	43	36
MNS3-0650-5XD	6.50		8	91	52	43	36
MNS3-0660-5XD	6.60		8	91	52	43	36
MNS3-0670-5XD	6.70	5/18-18UNF	8	91	53	43	36
MNS3-0675-5XD	6.75		8	91	53	43	36
MNS3-0680-5XD	6.80		8	91	53	43	36
MNS3-0690-5XD	6.90	M8	8	91	53	43	36
MNS3-0700-5XD	7.00		8	91	53	43	36
MNS3-0710-5XD	7.10	MF8x1	8	91	53	43	36
MNS3-0720-5XD	7.20		8	91	53	43	36
MNS3-0730-5XD	7.30		8	91	53	43	36
MNS3-0740-5XD	7.40		8	91	54	43	36
MNS3-0750-5XD	7.50		8	91	54	43	36
MNS3-0760-5XD	7.60		8	91	54	43	36
MNS3-0770-5XD	7.70		8	91	54	43	36
MNS3-0780-5XD	7.80		8	91	54	43	36
MNS3-0790-5XD	7.90		8	91	54	43	36
MNS3-0800-5XD	8.00		10	103	61	49	40
MNS3-0810-5XD	8.10		10	103	61	49	40
MNS3-0820-5XD	8.20	3/8-16 UNC	10	103	61	49	40
MNS3-0830-5XD	8.30		10	103	61	49	40

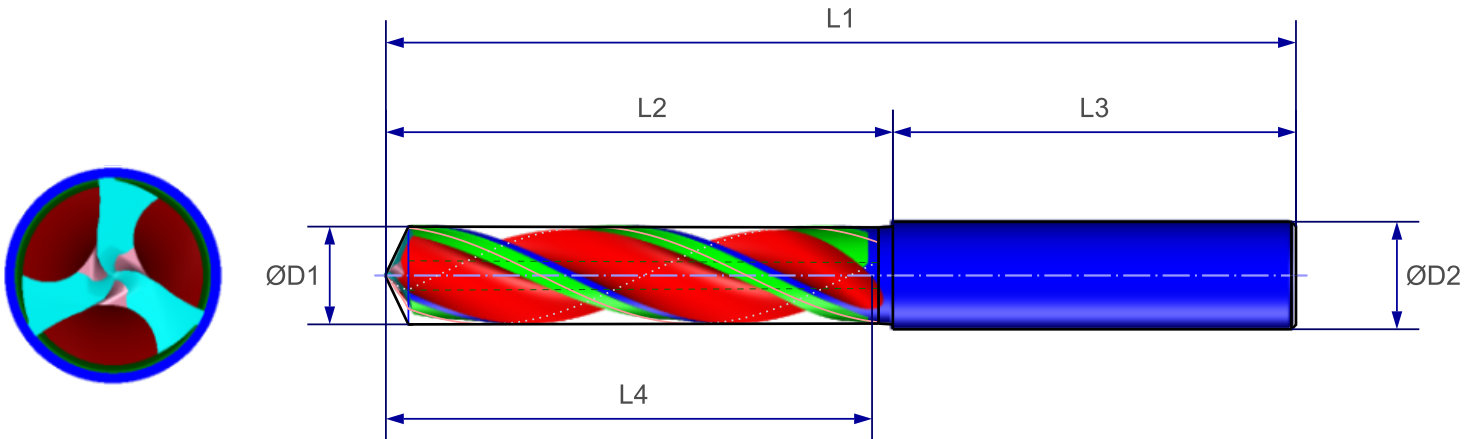

MNS3-0840-5XD	8.40		10	103	61	49	40	
MNS3-0850-5XD	8.50		10	103	61	49	40	
MNS3-0860-5XD	8.60	3/8-24 UNF	10	103	61	49	40	
MNS3-0870-5XD	8.70	M10	10	103	62	49	40	
MNS3-0880-5XD	8.80		10	103	62	49	40	
MNS3-0890-5XD	8.90	MF10x1.25	10	103	62	49	40	
MNS3-0900-5XD	9.00		10	103	62	49	40	
MNS3-0910-5XD	9.10		10	103	62	49	40	
MNS3-0920-5XD	9.20		10	103	62	49	40	
MNS3-0930-5XD	9.30		10	103	62	49	40	
MNS3-0940-5XD	9.40		10	103	63	49	40	
MNS3-0950-5XD	9.50		10	103	63	49	40	
MNS3-0960-5XD	9.60		10	103	63	49	40	
MNS3-0970-5XD	9.70		10	103	63	49	40	
MNS3-0980-5XD	9.70		10	103	63	49	40	
MNS3-0990-5XD	9.90		10	103	63	49	40	
MNS3-1000-5XD	10.00	7/16-20 UNF	12	118	71	56	45	
MNS3-1010-5XD	10.10		12	118	71	56	45	
MNS3-1020-5XD	10.20		12	118	71	56	45	
MNS3-1030-5XD	10.30		12	118	71	56	45	
MNS3-1040-5XD	10.40	M12	12	118	71	56	45	
MNS3-1050-5XD	10.50		12	118	71	56	45	
MNS3-1060-5XD	10.60		12	118	71	56	45	
MNS3-1070-5XD	10.70	MF12x1.5	12	118	72	56	45	
MNS3-1080-5XD	10.80		12	118	72	56	45	
MNS3-1090-5XD	10.90		12	118	72	56	45	
MNS3-1100-5XD	11.00	1/2-13 UNC	12	118	72	56	45	
MNS3-1110-5XD	11.10		12	118	72	56	45	
MNS3-1120-5XD	11.20		12	118	72	56	45	

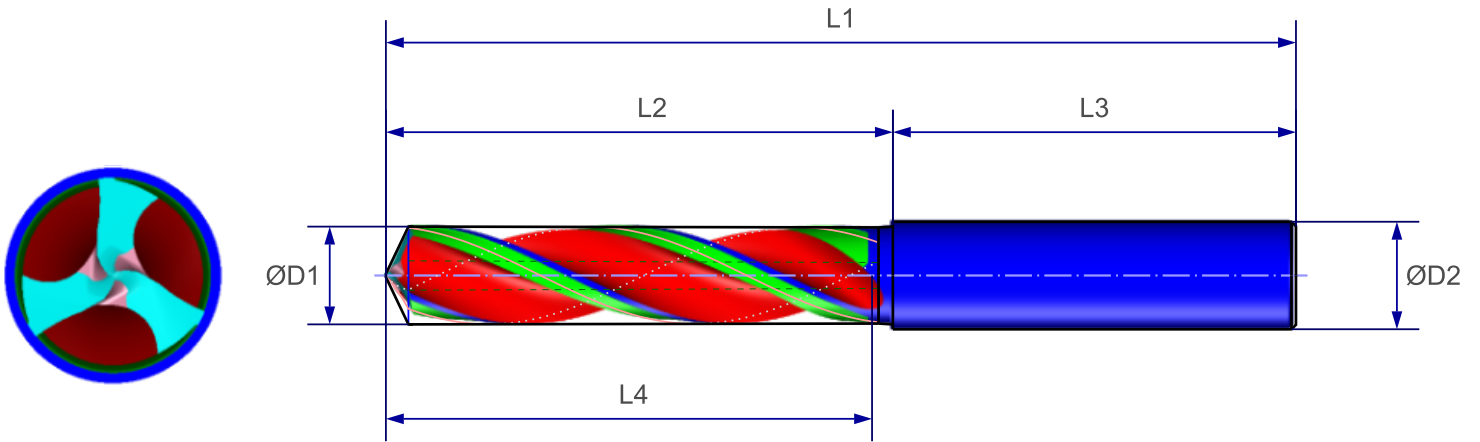

MNS3-1140-5XD	11.40		12	118	73	56	45
MNS3-1150-5XD	11.50		12	118	73	56	45
MNS3-1160-5XD	11.60	1/2-20 UNF	12	118	73	56	45
MNS3-1170-5XD	11.70		12	118	73	56	45
MNS3-1180-5XD	11.80		12	118	73	56	45
MNS3-1190-5XD	11.90		12	118	73	56	45
MNS3-1200-5XD	12.00		14	124	78	60	45
MNS3-1210-5XD	12.10		14	124	78	60	45
MNS3-1220-5XD	12.20		14	124	78	60	45
MNS3-1230-5XD	12.30		14	124	78	60	45
MNS3-1250-5XD	12.50		14	124	78	60	45
MNS3-1260-5XD	12.60		14	124	78	60	45
MNS3-1270-5XD	12.70		14	124	79	60	45
MNS3-1280-5XD	12.80		14	124	79	60	45
MNS3-1290-5XD	12.90		14	124	79	60	45
MNS3-1300-5XD	13.00		14	124	79	60	45
MNS3-1310-5XD	13.10		14	124	79	60	45
MNS3-1320-5XD	13.20		14	124	79	60	45
MNS3-1330-5XD	13.30		14	124	79	60	45
MNS3-1350-5XD	13.50		14	124	80	60	45
MNS3-1380-5XD	13.80		14	124	80	60	45
MNS3-1400-5XD	14.00		16	133	84	63	48
MNS3-1410-5XD	14.10		16	133	84	63	48
MNS3-1420-5XD	14.20		16	133	84	63	48
MNS3-1430-5XD	14.30		16	133	84	63	48
MNS3-1440-5XD	14.40		16	133	84	63	48
MNS3-1450-5XD	14.50		16	133	84	63	48
MNS3-1460-5XD	14.60		16	133	84	63	48
MNS3-1480-5XD	14.80		16	133	85	63	48

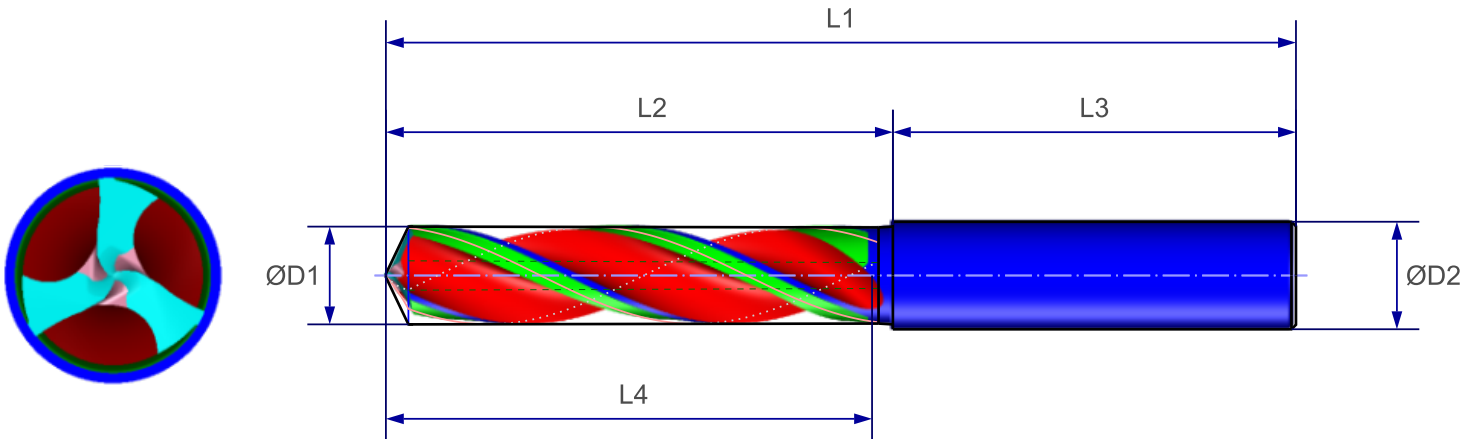

MNS3-1500-5XD	15.00		16	133	85	63	48	
MNS3-1510-5XD	15.10		16	133	85	63	48	
MNS3-1520-5XD	15.20		16	133	85	63	48	
MNS3-1530-5XD	15.30		16	133	85	63	48	
MNS3-1540-5XD	15.40		16	133	86	63	48	
MNS3-1550-5XD	15.50		16	133	86	63	48	
MNS3-1560-5XD	15.60		16	133	86	63	48	
MNS3-1570-5XD	15.70		16	133	86	63	48	
MNS3-1580-5XD	15.80		16	133	86	63	48	
MNS3-1590-5XD	15.90		16	133	86	63	48	
MNS3-1600-5XD	16.00		18	143	95	71	48	
MNS3-1610-5XD	16.10		18	143	95	71	48	
MNS3-1650-5XD	16.50		18	143	95	71	48	
MNS3-1700-5XD	17.00		18	143	96	71	48	
MNS3-1750-5XD	17.50		18	143	97	71	48	
MNS3-1770-5XD	17.70		18	143	97	71	48	
MNS3-1800-5XD	18.00		20	153	104	77	50	
MNS3-1840-5XD	18.40		20	153	104	77	50	
MNS3-1850-5XD	18.50		20	153	104	77	50	
MNS3-1900-5XD	19.00		20	153	105	77	50	
MNS3-1910-5XD	19.10		20	153	105	77	50	
MNS3-1920-5XD	19.20		20	153	105	77	50	
MNS3-1930-5XD	19.30		20	153	105	77	50	
MNS3-1950-5XD	19.50		20	153	106	77	50	
MNS3-2000-5XD	20.00		20	153	107	77	50	

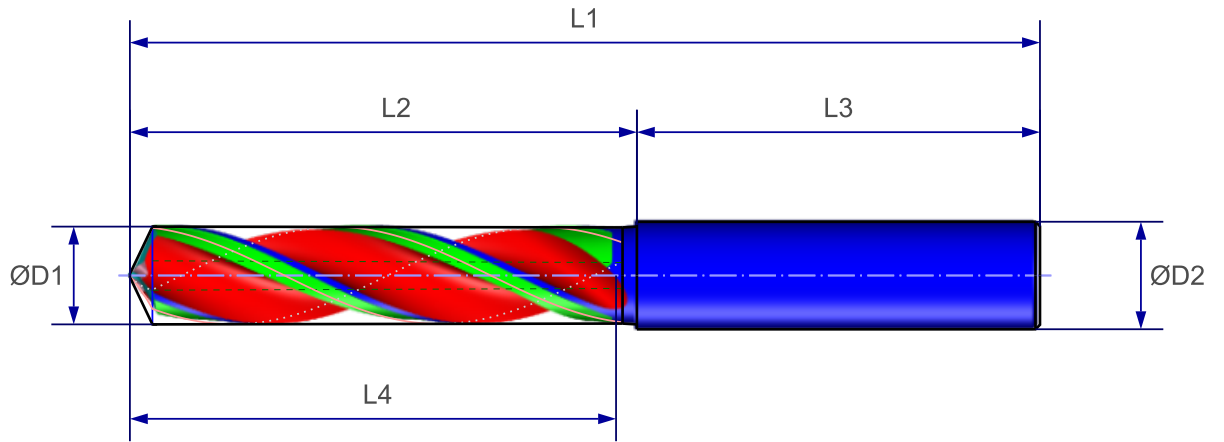
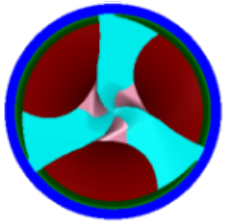

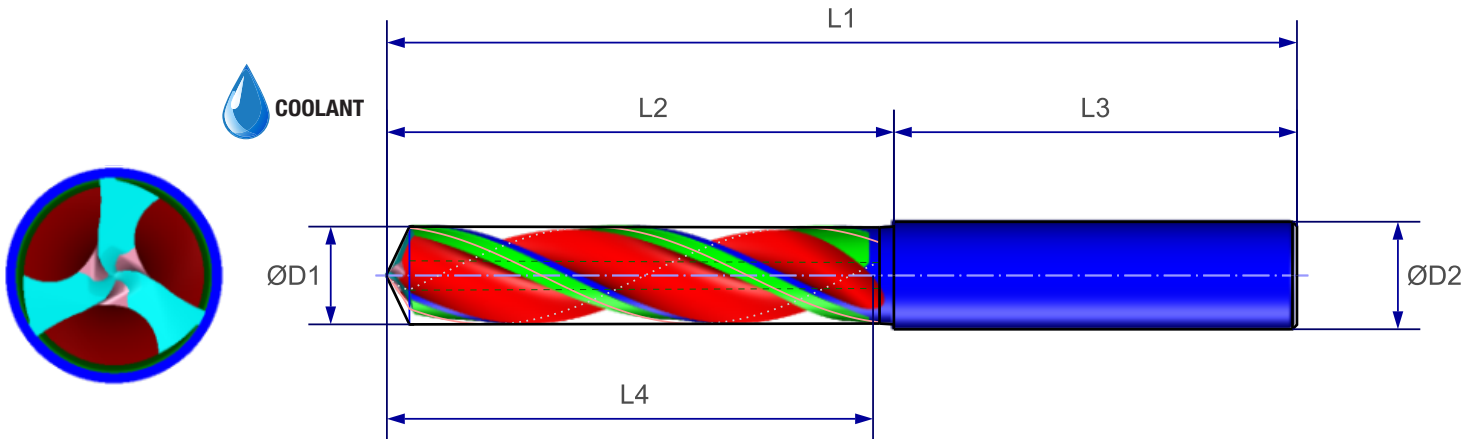

DESCRIPTION EXAMPLE... M=METRIC,N=NON FERROUS, C=COOLANT, 3=FLUTES, 3=Met- ric DIA 5XD=FLUTE LENGTH	DRILL DIAMETER D1 mm m7	DRILLS FOR THREADS	SHANK DIAM- ETER D2	OAL L1 mm	FLUTE LENGTH L2 mm	DRILLING DEPTH L3 mm	SHANK LENGTH L4 mm
MNC3-0300-5XD	3.00		6	66	27	23	36
MNC3-0310-5XD	3.10		6	66	27	23	36
MNC3-0320-5XD	3.20		6	66	27	23	36
MNC3-0330-5XD	3.30		6	66	27	23	36
MNC3-0340-5XD	3.40	M4	6	66	28	23	36
MNC3-0350-5XD	3.50		6	66	28	23	36
MNC3-0360-5XD	3.60		6	66	28	23	36
MNC3-0370-5XD	3.70		6	66	28	23	36
MNC3-0380-5XD	3.80		6	74	34	29	36
MNC3-0390-5XD	3.90	10-24 UNC	6	74	34	29	36
MNC3-0400-5XD	4.00		6	74	35	29	36
MNC3-0410-5XD	4.10	10-32 UNC	6	74	35	29	36
MNC3-0420-5XD	4.20		6	74	35	29	36
MNC3-0430-5XD	4.30	M5	6	74	35	29	36
MNC3-0440-5XD	4.40		6	74	35	29	36
MNC3-0450-5XD	4.50		6	74	35	29	36
MNC3-0470-5XD	4.70		6	74	36	29	36
MNC3-0480-5XD	4.80	12-32 UNC	6	82	42	35	36
MNC3-0490-5XD	4.90		6	82	42	35	36
MNC3-0500-5XD	5.00		6	82	42	35	36
MNC3-0510-5XD	5.10	M6	6	82	42	35	36
MNC3-0520-5XD	5.20		6	82	42	35	36
MNC3-0530-5XD	5.30	1/4-20 UNC	6	82	42	35	36
MNC3-0540-5XD	5.40		6	82	43	35	36
MNC3-0550-5XD	5.50		6	82	43	35	36

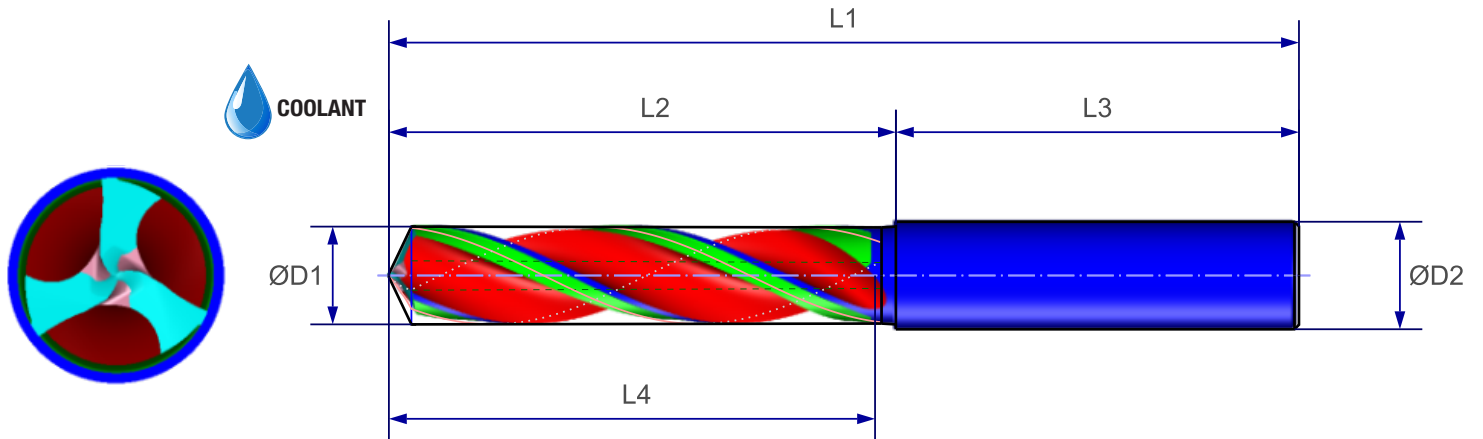

MNC3-0560-5XD	5.60		6	82	43	35	36
MNC3-0570-5XD	5.70		6	82	43	35	36
MNC3-0580-5XD	5.80		6	82	43	35	36
MNC3-0590-5XD	5.90		6	82	43	35	36
MNC3-0600-5XD	6.00		8	91	52	43	36
MNC3-0610-5XD	6.10		8	91	52	43	36
MNC3-0620-5XD	6.20		8	91	52	43	36
MNC3-0630-5XD	6.30		8	91	52	43	36
MNC3-0640-5XD	6.40		8	91	52	43	36
MNC3-0650-5XD	6.50		8	91	52	43	36
MNC3-0660-5XD	6.60		8	91	52	43	36
MNC3-0670-5XD	6.70	5/18-18UNF	8	91	53	43	36
MNC3-0675-5XD	6.75		8	91	53	43	36
MNC3-0680-5XD	6.80		8	91	53	43	36
MNC3-0690-5XD	6.90	M8	8	91	53	43	36
MNC3-0700-5XD	7.00		8	91	53	43	36
MNC3-0710-5XD	7.10	MF8x1	8	91	53	43	36
MNC3-0720-5XD	7.20		8	91	53	43	36
MNC3-0730-5XD	7.30		8	91	53	43	36
MNC3-0740-5XD	7.40		8	91	54	43	36
MNC3-0750-5XD	7.50		8	91	54	43	36
MNC3-0760-5XD	7.60		8	91	54	43	36
MNC3-0770-5XD	7.70		8	91	54	43	36
MNC3-0780-5XD	7.80		8	91	54	43	36
MNC3-0790-5XD	7.90		8	91	54	43	36
MNC3-0800-5XD	8.00		10	103	61	49	40
MNC3-0810-5XD	8.10		10	103	61	49	40
MNC3-0820-5XD	8.20	3/8-16 UNC	10	103	61	49	40
MNC3-0830-5XD	8.30		10	103	61	49	40

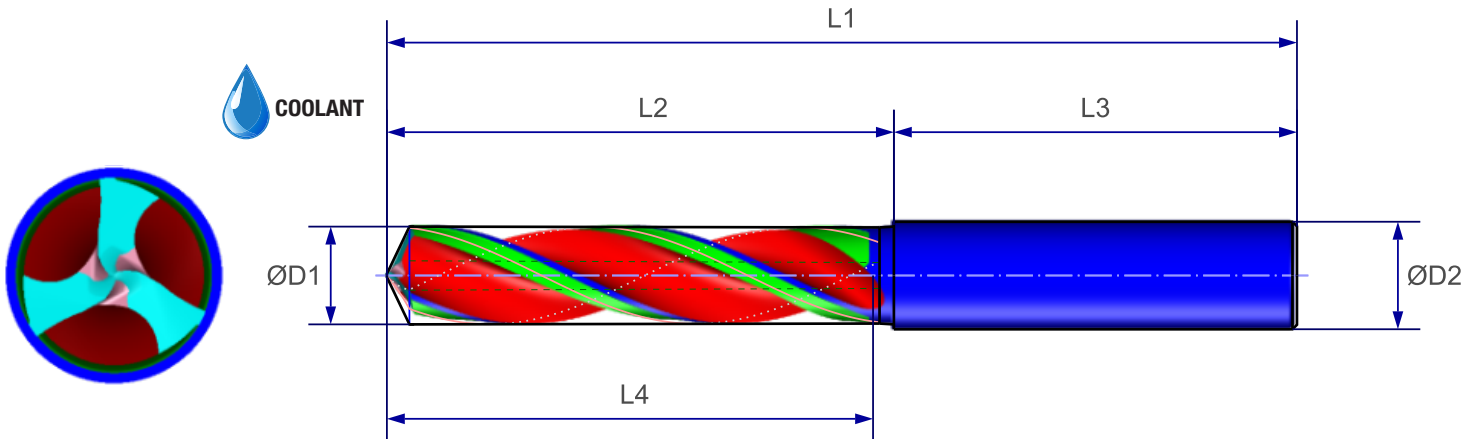

MNC3-0840-5XD	8.40		10	103	61	49	40
MNC3-0850-5XD	8.50		10	103	61	49	40
MNC3-0860-5XD	8.60	3/8-24 UNF	10	103	61	49	40
MNC3-0870-5XD	8.70	M10	10	103	62	49	40
MNC3-0880-5XD	8.80		10	103	62	49	40
MNC3-0890-5XD	8.90	MF10x1.25	10	103	62	49	40
MNC3-0900-5XD	9.00		10	103	62	49	40
MNC3-0910-5XD	9.10		10	103	62	49	40
MNC3-0920-5XD	9.20		10	103	62	49	40
MNC3-0930-5XD	9.30		10	103	62	49	40
MNC3-0940-5XD	9.40		10	103	63	49	40
MNC3-0950-5XD	9.50		10	103	63	49	40
MNC3-0960-5XD	9.60		10	103	63	49	40
MNC3-0970-5XD	9.70		10	103	63	49	40
MNC3-0980-5XD	9.70		10	103	63	49	40
MNC3-0990-5XD	9.90		10	103	63	49	40
MNC3-1000-5XD	10.00	7/16-20 UNF	12	118	71	56	45
MNC3-1010-5XD	10.10		12	118	71	56	45
MNC3-1020-5XD	10.20		12	118	71	56	45
MNC3-1030-5XD	10.30		12	118	71	56	45
MNC3-1040-5XD	10.40	M12	12	118	71	56	45
MNC3-1050-5XD	10.50		12	118	71	56	45
MNC3-1060-5XD	10.60		12	118	71	56	45
MNC3-1070-5XD	10.70	MF12x1.5	12	118	72	56	45
MNC3-1080-5XD	10.80		12	118	72	56	45
MNC3-1090-5XD	10.90		12	118	72	56	45
MNC3-1100-5XD	11.00	1/2-13 UNC	12	118	72	56	45
MNC3-1110-5XD	11.10		12	118	72	56	45
MNC3-1120-5XD	11.20		12	118	72	56	45

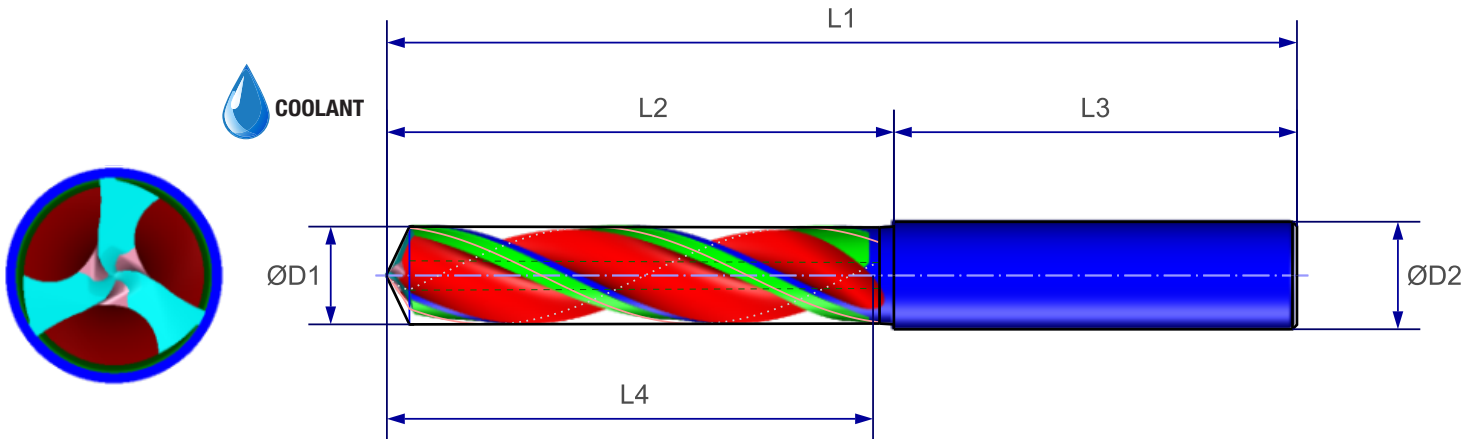

MNC3-1140-5XD	11.40		12	118	73	56	45
MNC3-1150-5XD	11.50		12	118	73	56	45
MNC3-1160-5XD	11.60	1/2-20 UNF	12	118	73	56	45
MNC3-1170-5XD	11.70		12	118	73	56	45
MNC3-1180-5XD	11.80		12	118	73	56	45
MNC3-1190-5XD	11.90		12	118	73	56	45
MNC3-1200-5XD	12.00		14	124	78	60	45
MNC3-1210-5XD	12.10		14	124	78	60	45
MNC3-1220-5XD	12.20		14	124	78	60	45
MNC3-1230-5XD	12.30		14	124	78	60	45
MNC3-1250-5XD	12.50		14	124	78	60	45
MNC3-1260-5XD	12.60		14	124	78	60	45
MNC3-1270-5XD	12.70		14	124	79	60	45
MNC3-1280-5XD	12.80		14	124	79	60	45
MNC3-1290-5XD	12.90		14	124	79	60	45
MNC3-1300-5XD	13.00		14	124	79	60	45
MNC3-1310-5XD	13.10		14	124	79	60	45
MNC3-1320-5XD	13.20		14	124	79	60	45
MNC3-1330-5XD	13.30		14	124	79	60	45
MNC3-1350-5XD	13.50		14	124	80	60	45
MNC3-1380-5XD	13.80		14	124	80	60	45
MNC3-1400-5XD	14.00		16	133	84	63	48
MNC3-1410-5XD	14.10		16	133	84	63	48
MNC3-1420-5XD	14.20		16	133	84	63	48
MNC3-1430-5XD	14.30		16	133	84	63	48
MNC3-1440-5XD	14.40		16	133	84	63	48
MNC3-1450-5XD	14.50		16	133	84	63	48
MNC3-1460-5XD	14.60		16	133	84	63	48

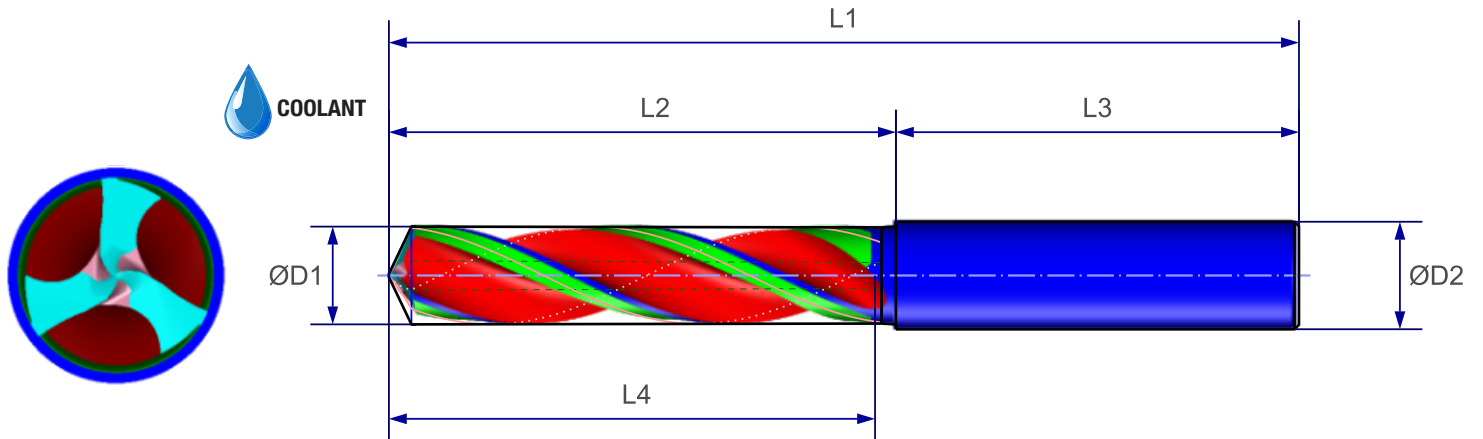

MNC3-1480-5XD	14.80		16	133	85	63	48	
MNC3-1500-5XD	15.00		16	133	85	63	48	
MNC3-1510-5XD	15.10		16	133	85	63	48	
MNC3-1520-5XD	15.20		16	133	85	63	48	
MNC3-1530-5XD	15.30		16	133	85	63	48	
MNC3-1540-5XD	15.40		16	133	86	63	48	
MNC3-1550-5XD	15.50		16	133	86	63	48	
MNC3-1560-5XD	15.60		16	133	86	63	48	
MNC3-1570-5XD	15.70		16	133	86	63	48	
MNC3-1580-5XD	15.80		16	133	86	63	48	
MNC3-1590-5XD	15.90		16	133	86	63	48	
MNC3-1600-5XD	16.00		18	143	95	71	48	
MNC3-1610-5XD	16.10		18	143	95	71	48	
MNC3-1650-5XD	16.50		18	143	95	71	48	
MNC3-1700-5XD	17.00		18	143	96	71	48	
MNC3-1750-5XD	17.50		18	143	97	71	48	
MNC3-1770-5XD	17.70		18	143	97	71	48	
MNC3-1800-5XD	18.00		20	153	104	77	50	
MNC3-1840-5XD	18.40		20	153	104	77	50	
MNC3-1850-5XD	18.50		20	153	104	77	50	
MNC3-1900-5XD	19.00		20	153	105	77	50	
MNC3-1910-5XD	19.10		20	153	105	77	50	
MNC3-1920-5XD	19.20		20	153	105	77	50	
MNC3-1930-5XD	19.30		20	153	105	77	50	
MNC3-1950-5XD	19.50		20	153	106	77	50	
MNC3-2000-5XD	20.00		20	153	107	77	50	

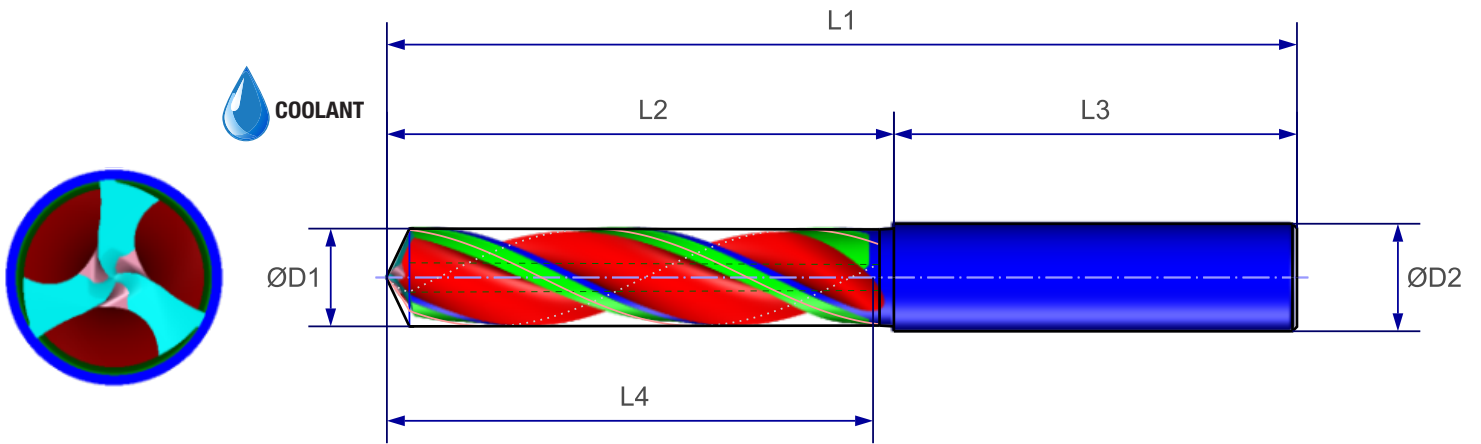

SPEED & FEED

Tool Diameter									
inch		0.125	0.188	0.25	0.313	0.375	0.5	0.625	0.75
mm		3.0	4.0	6.0	8.0	10.0	12.0	16.0	20.0

3-Flute Wrought Aluminum Alloys													
Cutting Speed		Min.	Start	Max	Feed Rate by Diameter								
SFM	Solid /Coolant	320	700	1300	IPR	.003-.007	.004-.008	.007-.013	.008-.015	.010-.017	.013-.020	.017-.023	.025-.031
Cast Aluminum													
Cutting Speed		Min.	Start	Max	Feed Rate by Diameter								
SFM	Solid /Coolant	320	650	800	IPR	.003-.007	.004-.008	.007-.013	.008-.015	.010-.017	.013-.020	.017-.023	.025-.031
Copper and Copper Alloys													
Cutting Speed		Min.	Start	Max	Feed Rate by Diameter								
SFM	Solid /Coolant	200	570	700	IPR	.003-.007	.004-.008	.007-.013	.008-.015	.010-.017	.013-.020	.017-.023	.025-.031